

TYPICAL BACKDROP DETAIL

INLET DIA. (mm)	DROP DIA. (mm)
225	300
300	375
375	375
450	450
525	450
600	450
750	600
900	600

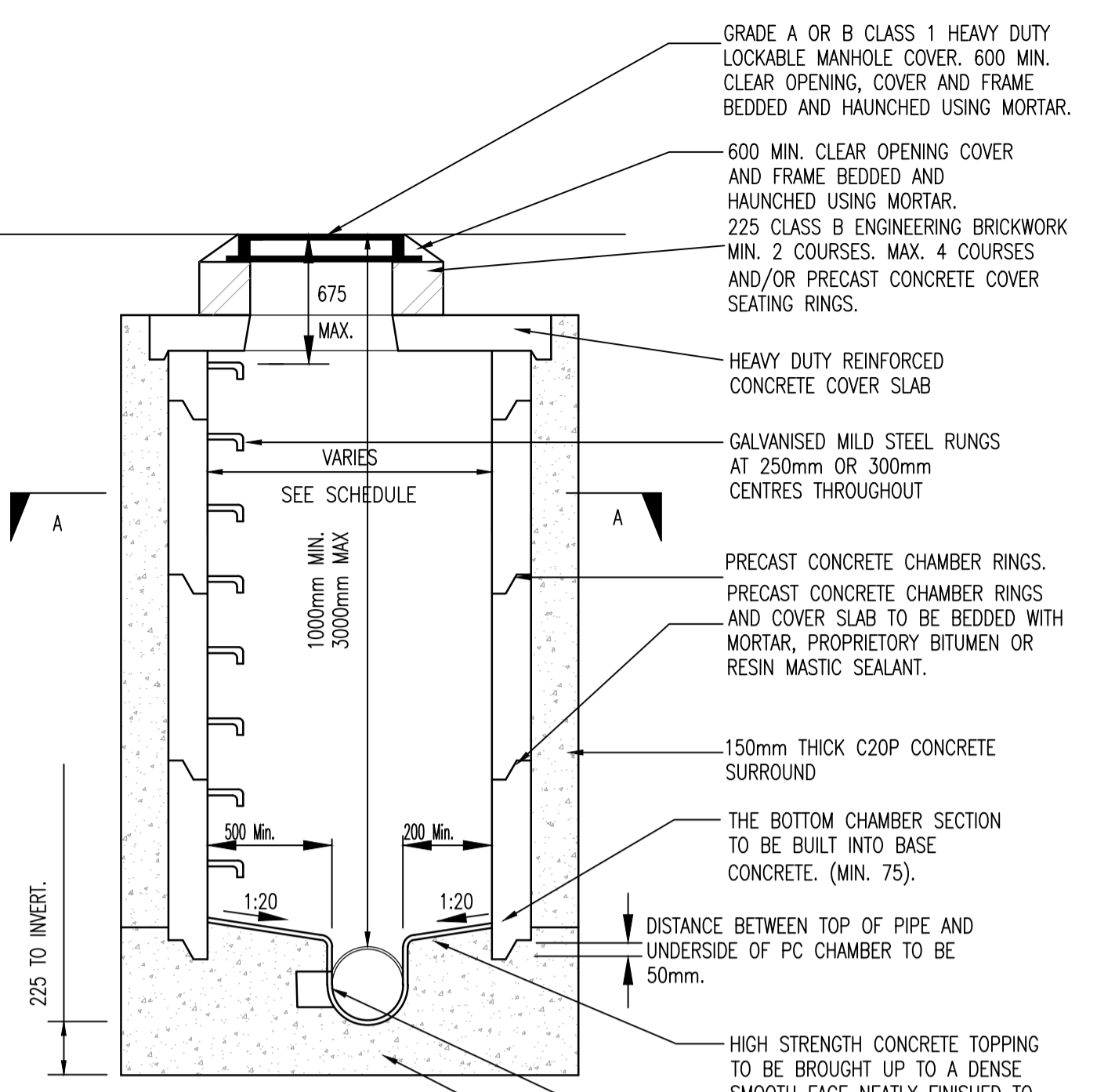

PRECAST CONCRETE RING MANHOLE DETAIL TYPE J (GSDS)

SCALE 1:25

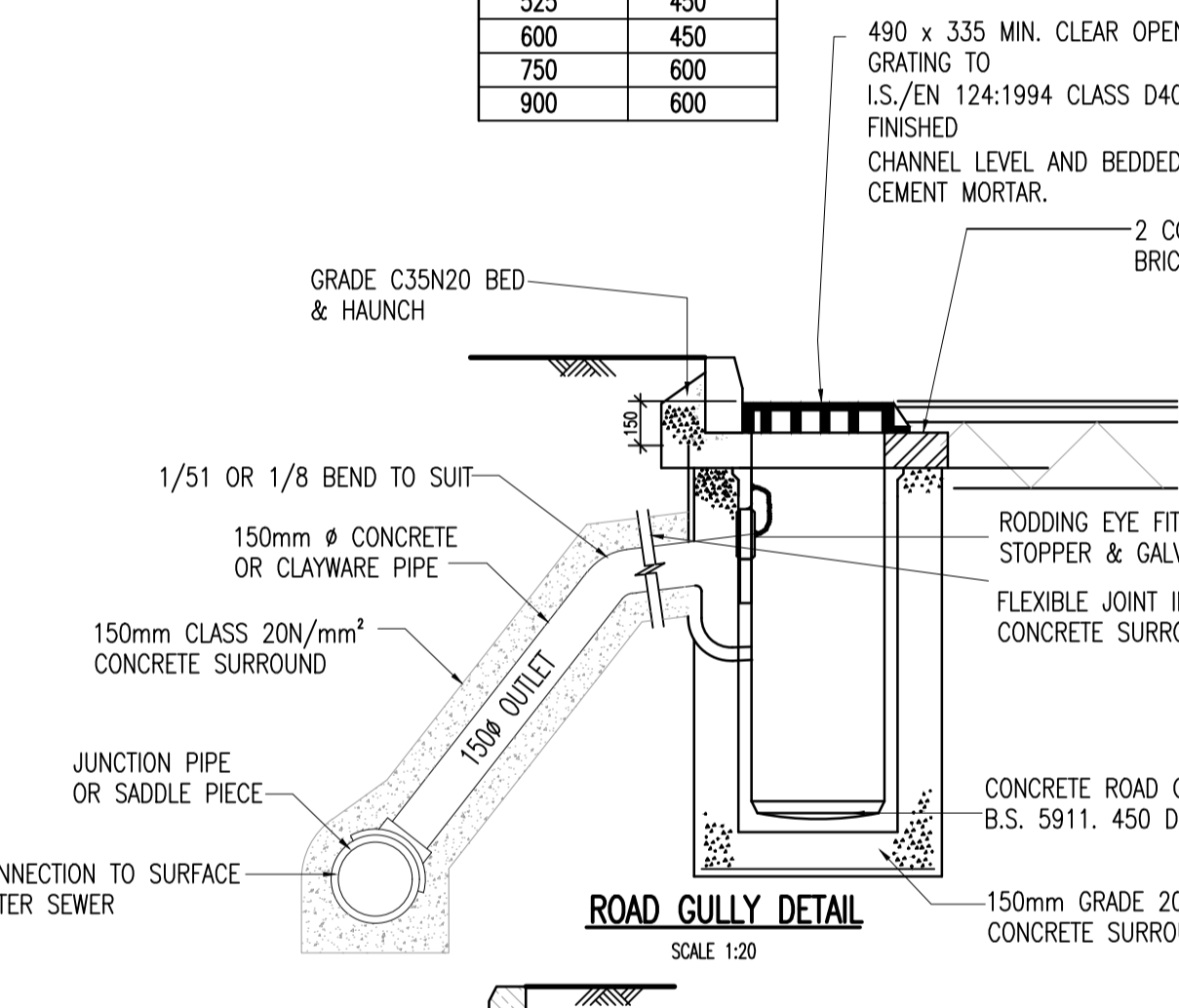

ROAD GULLY DETAIL

SCALE 1:20

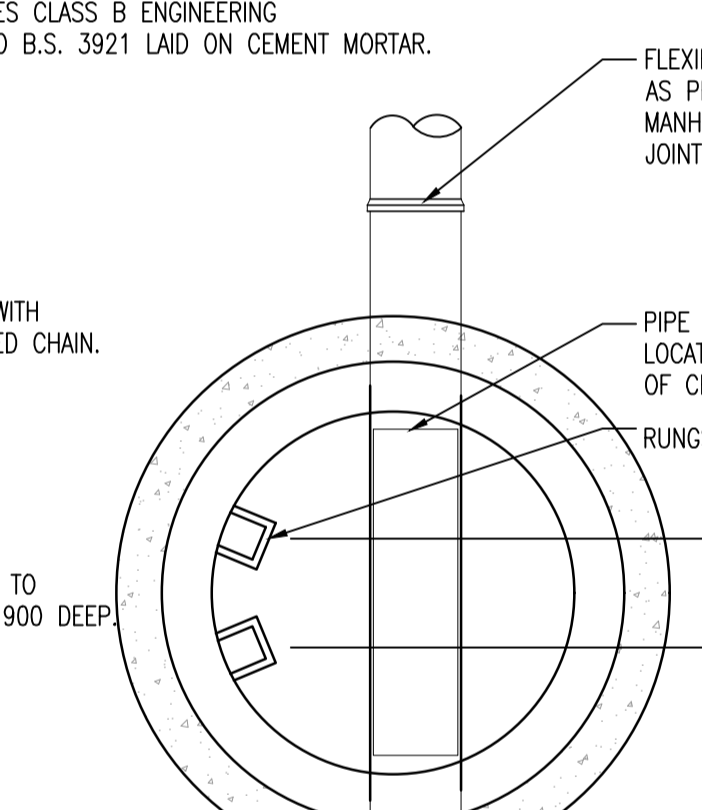

SECTION A-A

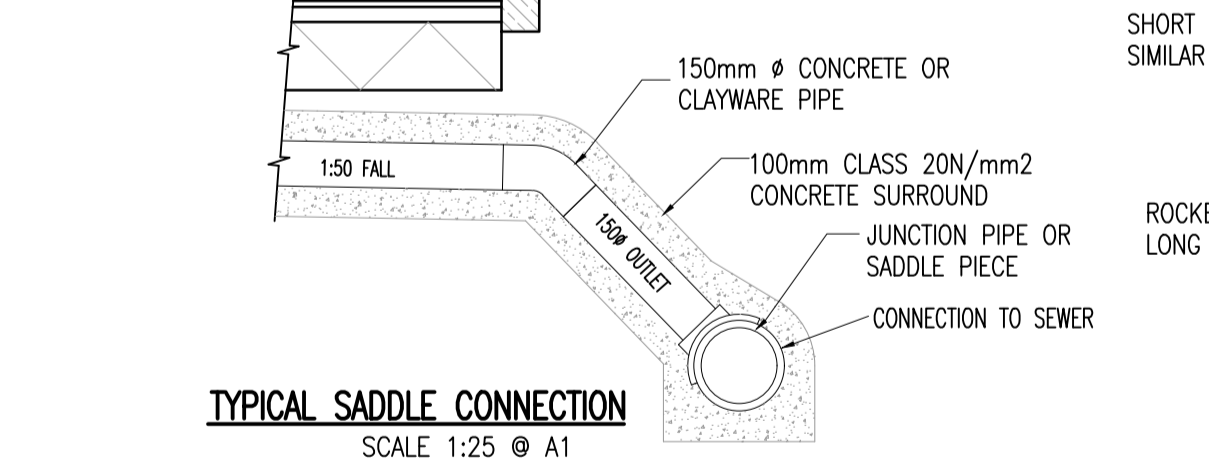

TYPICAL SADDLE CONNECTION

SCALE 1:25 @ A1

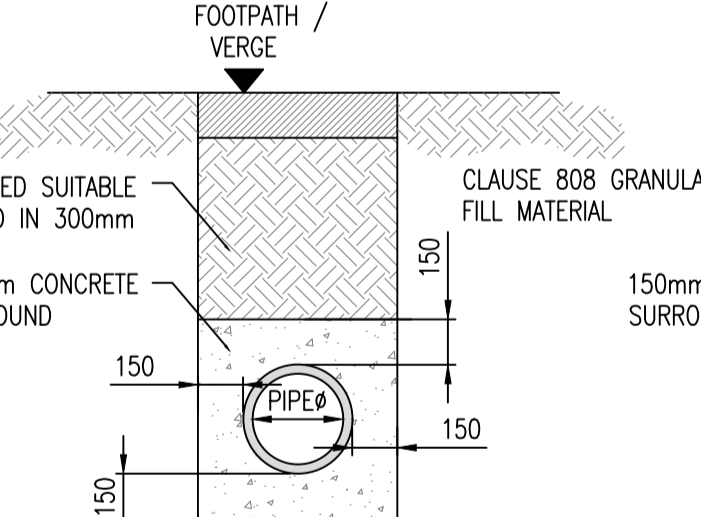

TYPICAL PIPE BEDDING DETAILS NON TRAFFICKED AREAS LESS THAN 900mm TO PIPE CROWN

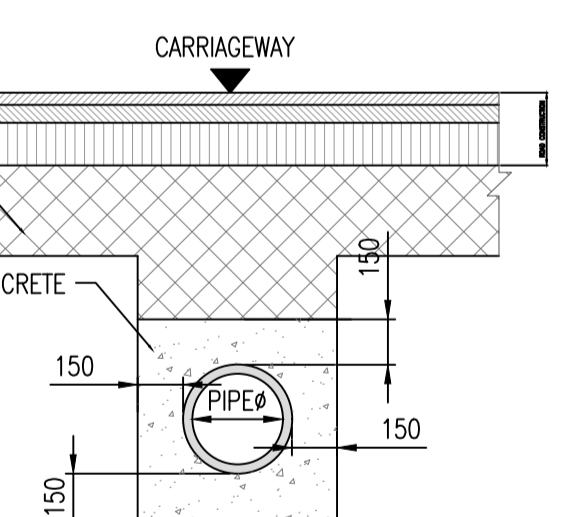

TYPICAL PIPE BEDDING DETAILS TRAFFICKED AREAS LESS THAN 1200mm TO PIPE CROWN

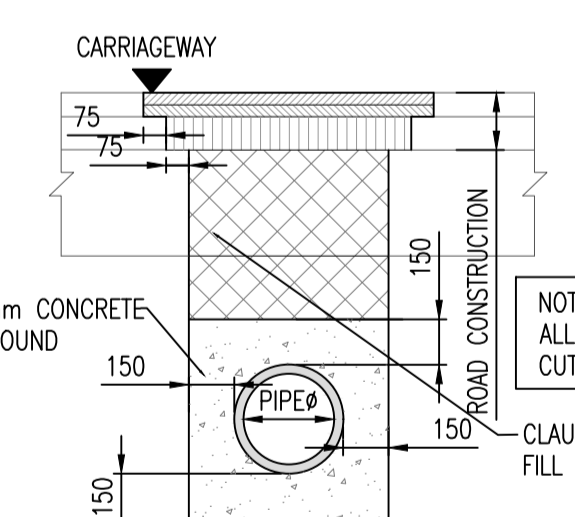

TYPICAL PIPE BEDDING AND REINSTATEMENT DETAILS TRAFFICKED AREAS (ROADWAY) LESS THAN 1200mm TO PIPE CROWN

SCALE 1:25

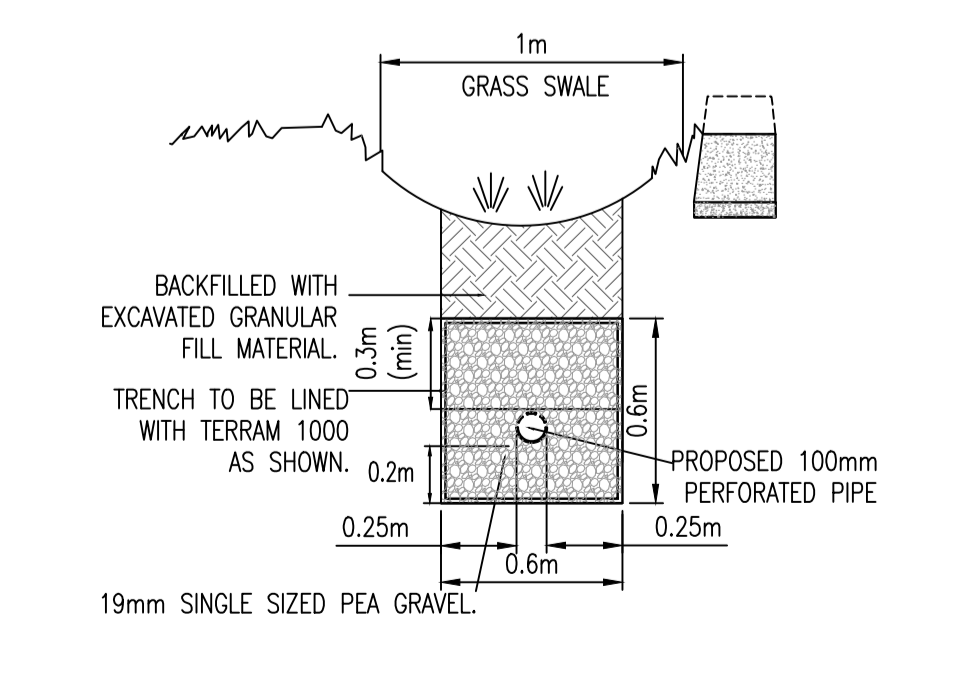

TYPICAL SECTION THROUGH PROPOSED SWALE

SCALE 1:25 @A1

NORMAL INTERNAL DIAMETER	MINIMUM TRENCH WIDTH mm	MAXIMUM TRENCH WIDTH mm
100	450	650
150	500	700
225	600	800
300	700	900
375	950	1150
450	1050	1250
525	1150	1350
600	1250	1450
675	1350	1550
750	1400	1600
825	1500	1700
900	1950	2150
1050	2100	2300
1200	2300	2500
ABOVE 1200	PIPE DIAMETER PLUS 800mm	OUTSIDE DIAMETER PLUS 1000mm

MAXIMUM AND MINIMUM TRENCH WIDTHS

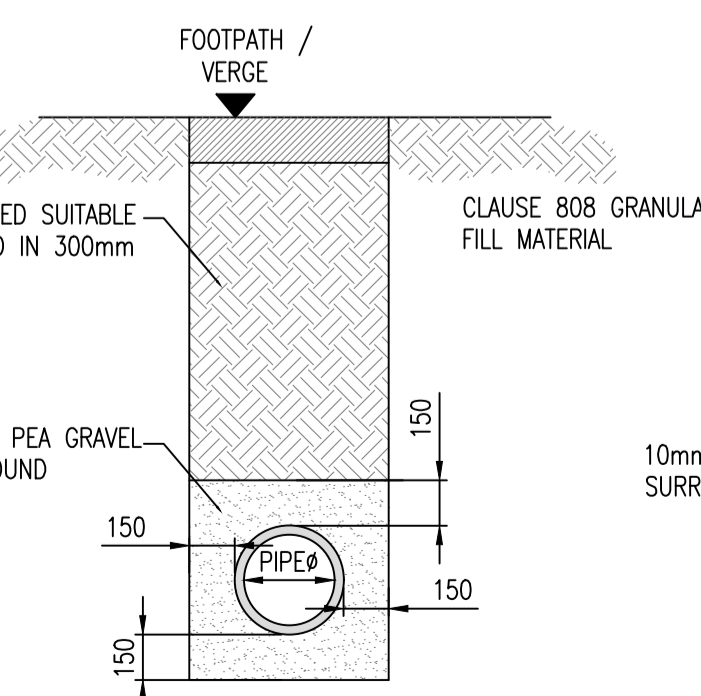

TYPICAL PIPE BEDDING DETAILS NON TRAFFICKED AREAS

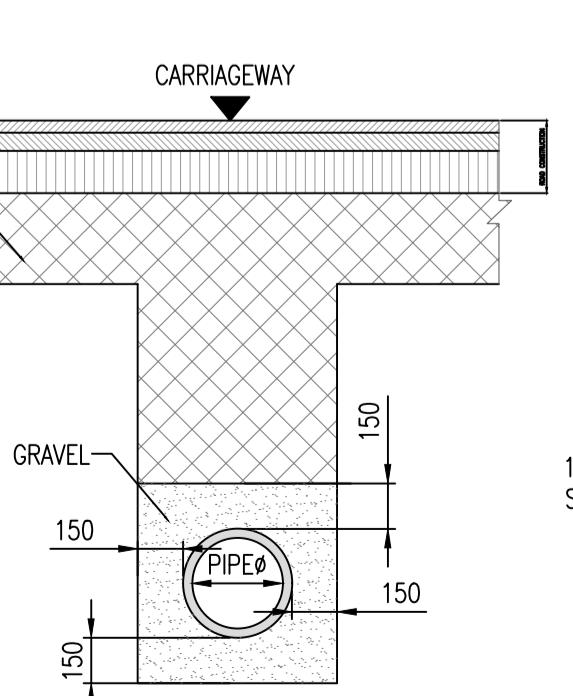

TYPICAL PIPE BEDDING DETAILS TRAFFICKED AREAS

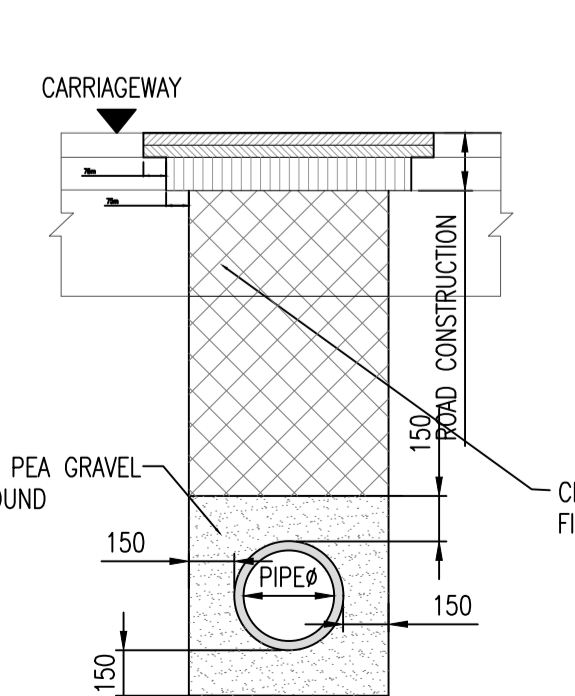

TYPICAL PIPE BEDDING AND REINSTATEMENT DETAILS

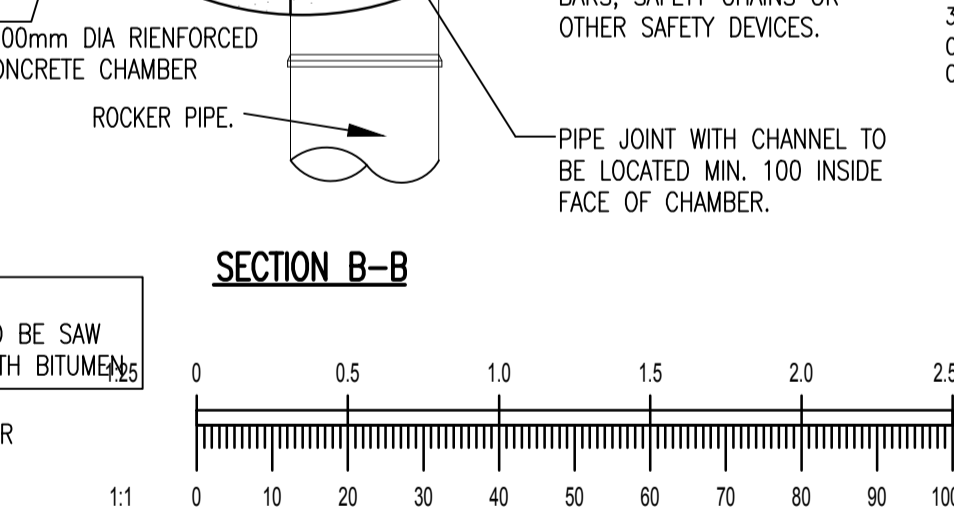

SECTION B-B

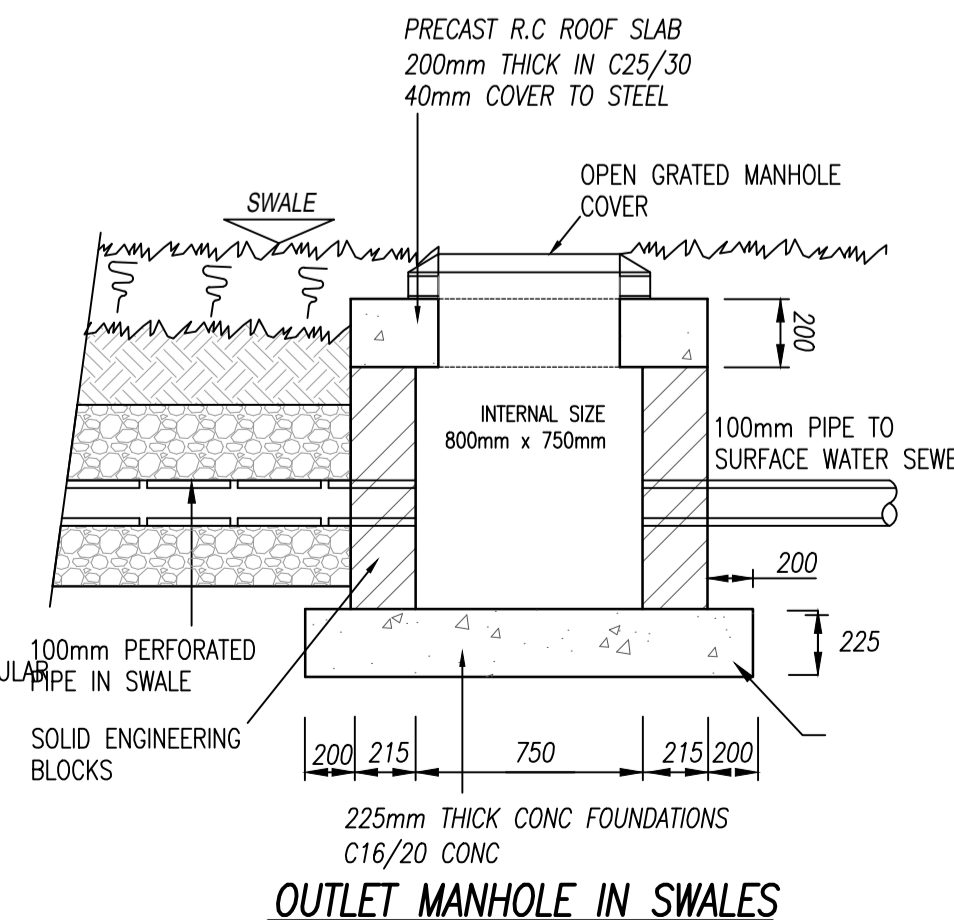
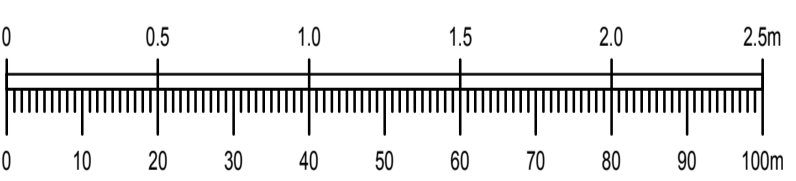

OUTLET MANHOLE IN SWALES

- NOTES:
- DO NOT SCALE. USE FIGURED DIMENSIONS ONLY.
 - THIS DRAWING IS TO BE READ IN CONJUNCTION WITH ALL OTHER RELEVANT ARCHITECTURAL AND ENGINEERING DRAWINGS.
 - ALL WORKS SHALL BE CONSTRUCTED STRICTLY IN ACCORDANCE WITH THE REQUIREMENTS OF LOUTH COUNTY COUNCIL.
 - TYPE A GRANULAR FILL SHALL CONSIST OF WASHED PEA GRAVEL. ALL MATERIAL SHALL PASS A 19mm B.S. TEST SIEVE AND SHALL BE RETAINED BY A 4.75mm B.S. TEST SIEVE.
 - SELECTED FILL SHALL BE FREE FROM STONES GREATER THAN 25mm IN SIZE. BUILDERS RUBBER, VEGETABLE MATTER AND LUMPS OF CLAY GREATER THAN 75mm IN SIZE AND SHALL BE COMPACTED IN 150mm LAYERS.
 - WHERE SUITABLE PREVIOUSLY EXCAVATED MATERIAL IS USED FOR BACKFILLING, THIS MATERIAL SHALL BE COMPACTED IN 300mm LAYERS.
 - CONCRETE BED AND SURROUND SHALL BE USED ON ALL PIPES WHERE COVER TO THE SOFT OF THE PIPE IS LESS THAN 1.2m IN ROADS, FOOTPATHS AND GRASS MARGINS AND 0.9m IN OPEN SPACES AND FIELDS.
 - ALL CONCRETE FOR PIPE BEDDING, HAUNCHING AND SURROUNDS SHALL BE GRADE 20N/40 UNLESS OTHERWISE STATED.
 - ALL PIPE TRENCHES / EXCAVATIONS SHALL BE BACKFILLED AND COMPACTED STRICTLY IN ACCORDANCE WITH REQUIREMENTS OF CLAUSE 808, NRA SPECIFICATION FOR ROAD WORKS.
 - ALL HOUSE DRAINS SHALL BE EITHER PVC, CONCRETE OR VITRIFIED CLAY IN ACCORDANCE WITH CURRENT IRISH STANDARDS.
 - ALL FOUL SEWERS SHALL BE EITHER IN-SITU CONCRETE OR BLOCKWORK WITH INTERIOR BRICK LINING.
 - PRIVATE DRAINS SHALL BE DISCONNECTED FROM PUBLIC SEWERS BY THE INSTALLATION OF AN INTERCEPTING TRAP.
 - PREFORMED HALF CIRCLE CHANNEL PIPES. THE PIPELINE MAY WHERE PRACTICABLE, BE LAID THROUGH THE MANHOLE AND THE CROWN BROKEN OUT TO HALF DIAMETER, PROVIDED FLEXIBLE JOINTS ARE SITUATED ON EACH SIDE NO FURTHER THAN 600mm. FROM THE INNER FACE OF MANHOLE WALL.
 - FOR SURFACE WATER MANHOLES HIGH DENSITY BLOCKS TO CL S10 OR IS.20 PART 1 : 1987 OR CL 30/20 INSTITU CONCRETE. BLOCKWORK SHALL BE BEDDED AND JOINTED USING MORTAR DESIGNATION 3 TO IS.406. BEDS AND VERTICAL JOINTS SHALL BE COMPLETELY FILLED WITH MORTAR AS THE BLOCKS ARE LAID. JOINTS SHALL BE FLUSH POINTED AS THE WORK PROCEEDS. ALL FOUL MANHOLES MUST BE FACED IN SOLID ENGINEERING BRICK (MIN. CLASS A OR B) OR INSTITU CONCRETE FOR 1 METRE ABOVE BENCHING LEVEL.
 - FOR MANHOLES > THAN 3m DEPTH TO INVERT USE 30N/20 IN-SITU CONCRETE REINFORCING MESH REF. A933 @ 6.18kg/m TO BE FIXED AT MID POINT OF WALL. ADDITIONAL REINFORCEMENT TO BE SUPPLIED OVER PIPE CROWN.
 - BRICK RELIEVING ARCH 113MM. THICK FOR PIPES 225MM. DIAM. OR LARGER. ALTERNATIVELY A REINFORCED CONCRETE LINTEL MAY BE USED. WORK SIZE OF BRICKS 215 X 103 X 65THK. RELIEVING ARCHES USED IN BRICK OR BLOCKWORK MANHOLES.
 - BENCHING AND PIPE CHANNEL PIPE SURROUND - CL. 22.5/20 CONCRETE.
 - BENCHING FINISHED IN 2:1 SAND-CEMENT MORTAR WITH A SMOOTH TROWEL FINISH. LEVEL WITH PIPE SOFFIT AT 1 IN 30 SLOPE TOWARDS CHANNEL.
 - GALVANISED RUNGS AT 300C/C VERTICALLY EMBEDDED TO A DEPTH OF 125mm INTO MANHOLE WALLS OVER BENCHING AS DIRECTED BY DRAINAGE ENGINEER.
 - O.P.E. IN ROOF SLAB POSITIONED SO THAT THE EDGE OF OPENING IN THE FRAME IS VERTICALLY ABOVE THE FRONT EDGE OF RUNGS OR LADDERS.
 - 200THK. INSTITU R.C. ROOF SLAB IN CL.30/20 CONCRETE. COVER TO STEEL SHALL BE 40MM.
 - 1 TO 2 NO. ENGINEERING BRICKS CL. B TO I.S. 91: 1983 SET IN 1:3 (CEMENT SAND MORTAR). 22B. AN ACCESS SHAFT 225mm THICK SHALL BE BUILT IN SOLID ENGINEERING BRICK CLASS A OR B OR IN SOLID CONCRETE BLOCKS DESIGNATION S10, STRENGTH 10N/mm² TO SEAT THE MANHOLE COVER AND FRAME. THE MINIMUM DEPTH OF SHAFT SHALL BE 450mm.
 - GRADE A MANHOLE COVER AND FRAME TO I.S.124: 1994 CLASS D400 NO.2 1988 SET ON 13MM THK. CEMENT MORTAR BED AND FRAMES HAUNCHED OVER SIDES WITH CEMENT MORTAR. MANHOLE COVERS SHALL HAVE A CLEAR O.P.E. OF 600mm. DIAM. FOR SEWERS LESS THAN 1M. DIAM. MANHOLE COVERS ON SEWERS 1M. DIAM. OR GREATER SHALL HAVE A 600 X 600 CLEAR O.P.E. MANHOLE COVERS SHALL BE AT LEAST 100MM. DEEP.
 - BACKDROP MANHOLES SHALL HAVE A HEAVY DUTY CLASS D400 COVER AND FRAME FITTED AT GROUND LEVEL TO THE INLET PIPE ON THE BACKDROP.
 - SHORT LENGTH PIPE, PIPE JOINT EXTERNAL TO MANHOLE SHALL NOT EXCEED 600mm FROM THE INNER FACE OF THE MANHOLE WALL. SHORT LENGTH PIPES SURROUNDED IN 150mm THICK CL. 22.5/20 CONCRETE.
 - WHEN DEPTH OF MANHOLES TO INVERT IS GREATER THAN 3.0M. LADDERS SHALL BE USED INSTEAD OF RUNGS. THEY SHOULD BE LOW CARBON STEEL AND HOT DIPPED AFTER FABRICATION.
 - LADDER STRINGERS SHOULD BE ADEQUATELY SUPPORTED FROM THE MANHOLE WALL AT INTERVALS OF NOT MORE THAN 3.0M. STRINGERS SHOULD BE BOLTED TO CLEATS TO FACILITATE REPAIR.
 - ALL LADDERS, RUNGS, HANDRAILS, SAFETY CHAINS ETC. SHALL BE HOT DIP GALVANISED TO B.S.729.
 - SOCKET OF PIPE MAY BE INSIDE MANHOLE FOR CONVENIENCE OF BRICK ARCH OVER PIPE.
 - ALL MANHOLES SHALL BE WATER TIGHT TO THE SATISFACTION OF THE ENGINEER.
 - FORMWORK TO REINFORCED CONCRETE AND MASS CONCRETE SHALL BE CLASS F2.
 - CLASS U2 FINISH TO THE TOP OF SLABS.
 - PLAN DIMENSIONS OF MANHOLES ARE BASED ON BLOCKWORK HAVING A CO-ORDINATING SIZE OF 450 X 225 X 100.
 - MANHOLES ARE DESIGNED TO B.S.8005 AND WALL THICKNESSES TO I.S.325 TAKING GRANULAR FILL PRESSURE AND H.B. SURCHARGE.
 - REINFORCEMENT TO SLABS TO ENGINEERS DETAILS.
 - CHAMBER SHALL BE FACED INTERNALLY WITH SOLID ENGINEERING BRICKS CLASS A OR B COMPLYING IS 91:1983 TIED INTO BLOCKWORK FOR A HEIGHT OF 1m OVER BENCHING. JOINTS SHALL BE FLUSH POINTED AS THE WORK PROCEEDS.
 - VERTICAL JOINTS SHALL BE COMPLETELY FILLED WITH MORTAR AS THE BLOCKS ARE LAID IN PLACE. MIN. WALL THICKNESS TO BE 225mm.
 - TOE HOLES OF 230mm MINIMUM DEPTH AND GALVANIZE STEEL SAFETY RAILINGS TO BE PROVIDED IN BENCHING AT SEWERS GREATER THAN 525mm DIA. AND DEPTH TO INVERT >3m FOR ACCESS TO INVERT.
 - A SAFETY CHAIN IS TO BE PROVIDED ON PIPES THAT EXCEEDS 450mm DIA. MILD STEEL SAFETY CHAIN SHALL BE 10mm NOMINAL SIZE GRADE M (H) NON-CALIBRATED CHAIN, TYPE 1, COMPLYING WITH BS 4942 PART 2 OR EQUIVALENT.

REV.	DATE	AMENDMENT	DRN	APPD

STATUS **FOR PLANNING ONLY NOT FOR CONSTRUCTION**

Waterman Moylan
Engineering Consultants
BLOCK S, EASTPOINT BUSINESS PARK, ALFIE BYRNE ROAD, DUBLIN D03 H3F4 IRELAND.
Tel: (01) 684 8900 Fax: (01) 681 3618
Email: info@waterman-moylan.ie www.waterman-moylan.ie

CLIENT	TRAILFORD LTD		
ARCHITECT	NDBA ARCHITECTS		
PROJECT	PROPOSED RESIDENTIAL DEVELOPMENT, RATHMULLAN, DROGHEDA		
TITLE	PUBLIC SURFACE WATER DRAINAGE DETAILS		
DRAWN	DESIGNED	APPROVED	DATE
G. Byrne	BW	J.G.	AUG. '19
SCALE	JOB NO.	DRG. NO.	REVISION
AS SHOWN @A1	18-014	P027	